

Measurement of the Thermal Conductivity of $\text{KNO}_3\text{-NaNO}_3$ Mixtures Using a Transient Hot-Wire Method with a Liquid Metal in a Capillary Probe

T. Omotani,¹ Y. Nagasaka,¹ and A. Nagashima¹

Received December 7, 1981

The thermal conductivity of $\text{KNO}_3\text{-NaNO}_3$ mixtures was measured by a modified transient hot-wire method using liquid metal in a capillary as a heat source. The method was developed for measurements on electrically conducting liquids at high temperatures. Measurements were performed on pure NaNO_3 and its three mixtures with KNO_3 in the temperature range from 498 to 593 K.

KEY WORDS: Mixtures; molten salts; potassium nitrate; sodium nitrate; thermal conductivity; transient method.

1. INTRODUCTION

Molten salts are considered to be excellent heat transfer fluids for breeder reactors, fusion reactors, thermal energy storage systems, and for various other energy conversion systems. Since they have a lower melting temperature than pure salts and numerous combinations, salt mixtures are especially attractive for a variety of applications. Among properties concerning the salt characteristics which are needed for designing plants, thermal conductivity is one of the most important.

Most of the available studies on the thermal conductivity of fluids have been carried out using the steady-state methods. A steady-state method is disadvantageous in measurements on a mixture since the existence of the temperature gradient in a mixture for a long period may cause separation of the components due to thermal diffusion. In this respect, a transient hot-wire method, which has been improved in recent years, is

¹Mechanical Engineering Department, Keio University, 3-14-1 Hiyoshi, Kohoku, Yokohama 223, Japan.

ideally suited to measurements on mixtures, in addition to such well-known advantages as convection free measurement and simple structure of the cell. The measuring period is so short that the thermal diffusion never seriously affects the process.

Unfortunately, salts are electrical conductors, and this prevents the application of a conventional transient hot-wire method for salts. In earlier studies, coating or sheathing of the wire was unsuccessfully tested at high temperatures. The reason for the failure was due to the differences in the thermal expansion coefficients of the wire and coating material. In the present study, a new improved method has been introduced; the thin metallic wire of a conventional hot-wire apparatus was replaced by a quartz glass capillary containing mercury. Troubles due to differences in the thermal expansivities have been completely eliminated.

Measurements were carried out on salt mixtures of the KNO_3 - NaNO_3 system, over a range of temperatures up to 593 K. In the case of KNO_3 - NaNO_3 mixtures, the two sets of available data showed considerably different tendencies with respect to each other; one set showed a minimum in conductivity at a certain composition, while the other showed a linear dependence on composition. The present study is intended to resolve this controversy.

2. COMPOSITION AND THE TEMPERATURE DEPENDENCE OF THERMAL CONDUCTIVITY

Thermal conductivity of the KNO_3 - NaNO_3 mixtures over the entire composition range was measured in the past by Bloom et al. [1] and by McDonald and Davis [2]. Using a concentric cylindrical apparatus, Bloom et al. measured thermal conductivity in the range 597 to 691 K. McDonald and Davis measured thermal conductivity at each melting point up to 733 K. The data of Bloom et al. showed a nonlinear dependence on composition and had a minimum value at $x = 0.6$, where x is the mole fraction of KNO_3 . On the other hand, the data of McDonald and Davis showed an almost linear dependence on composition. The scatter of the data on NaNO_3 obtained by Bloom et al. seemed to be too great in comparison to those obtained by others. Also, there were disagreements in the temperature dependence of thermal conductivity for NaNO_3 by various investigators; some showed a positive temperature dependence, while others showed no dependence at all. Considering these large discrepancies among the available data on both pure components and their mixtures, it was necessary to establish new and more definitive experimental data. These new data should be based on more precise measurements and, preferably, on measurements using a different principle.

3. PRINCIPLE AND APPARATUS

The principle and special features of the transient hot-wire method were reported in detail in earlier reports, and can be seen in ref. [3]. The most important point of this method is that it can eliminate any error due to convection. This feature is especially attractive for measuring high temperature fluids. A "liquid-metal probe" made it possible to apply the transient hot-wire method to electrically conducting liquids at high temperatures. Cracking of the coating layer due to a difference in thermal expansion or solid surface contact resistance between sheath and wire will not occur with this probe. Details of the probe are shown in Fig. 1. The outline of this method and its experimental verification are described in ref. [4]. But, later, it was found that the electrical resistance of pyrex glass used in the above reference deteriorates at temperatures above 520 K. The material of the capillary was changed to quartz glass in the present study,

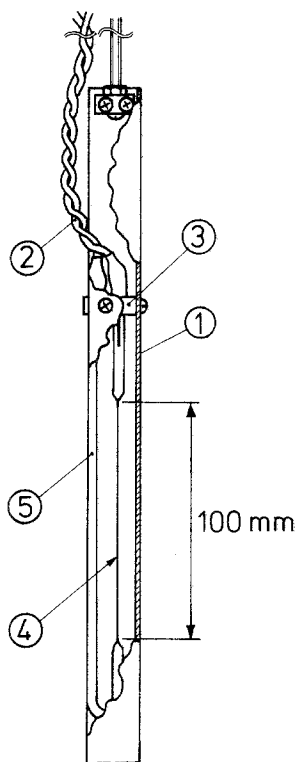

Fig. 1. Details of the liquid-metal probe. 1, guard plate (stainless steel); 2, lead wire; 3, holder (aluminum); 4, capillary (quartz glass); 5, glass tube (quartz glass).

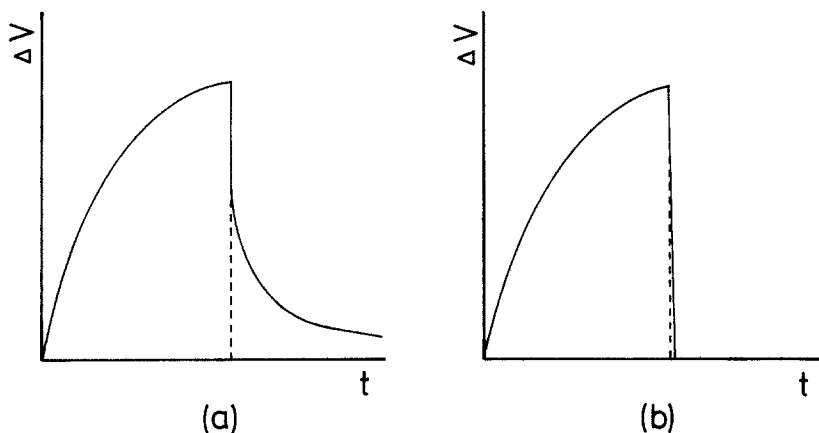

Fig. 2. Switch-off characteristics (300°C): (a) pyrex glass; (b) quartz glass.

which has much smaller electrical conductivity, even at high temperatures, in comparison to pyrex glass. Figures 2a and 2b show the typical switch-off characteristics for pyrex glass and quartz glass capillaries at 300°C, respectively. The electrical circuit is shown in Fig. 3. The probe consists of one section of a double bridge. After electrical current is supplied to the probe,

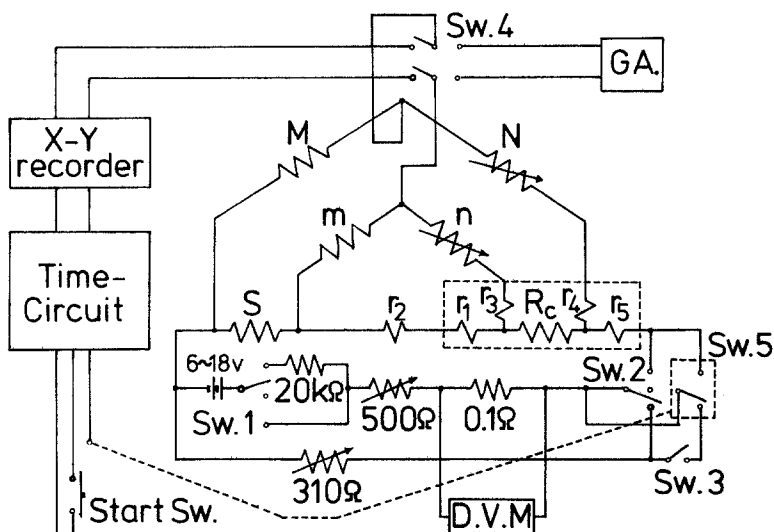

Fig. 3. Electrical circuit of the transient hot-wire apparatus.

the resistance of the probe is measured. Unbalanced voltage, ΔV , was recorded against the logarithm of time with a X - Y recorder. By simplifying the solution of the heat conduction equation for a thin line heat source in an infinite medium [5], on the condition that the Fourier number is large enough, the working equation for the present system was obtained to be as follows:

$$\lambda = \frac{1}{4\pi l_e} \frac{dR}{dT} \frac{RS}{R+S} I^3 / \left(\frac{d\Delta V}{d \ln t} \right) \quad (1)$$

where λ is the thermal conductivity, l_e is the effective length of the probe calibrated using toluene, I is the electric current, T is the temperature, t is the time, ΔV is the unbalanced voltage, and R and S are resistances shown in Fig. 3. In the present apparatus, the test section was not made of uniform material, but consisted of a mercury thread surrounded by a thin quartz glass cylinder. In order to test the applicability of Eq. (1) to this system, variations of unbalanced voltage ΔV against the logarithm of time ($\ln t$) were recorded, and the linearity was confirmed for the present probe. An example, with a more in depth analysis, of the effects of the insulation layer was reported by Nagasaka and Nagashima [6].

The instrument was calibrated against the thermal conductivity of toluene [3],

$$\lambda = 0.1378_2 - 2.91_4 \times 10^{-4}\theta \quad (2)$$

where λ is in $\text{W} \cdot \text{m}^{-1} \cdot \text{K}^{-1}$ and θ is in $^\circ\text{C}$.

Measurements of the salts were carried out on a relative basis since the length of the test section was not clearly established due to the small tapered parts on both ends of the capillary. The effective length of the test section was calculated from the data on toluene. In a previous study [4], similar measurements were also carried out with water and glycerin. The results of the effective length for the three reference substances were in agreement well within the experimental error.

4. RESULTS AND DISCUSSION

For each condition, at least five independent measurements were performed in order to check the reproducibility of the measurements. The averaged values of these repeated measurements are listed in Table I. The deviation of each measurement from the averaged value did not exceed 2.1%. The majority of the experimental errors were due to the uncertainties

Table I. Measured Thermal Conductivity of $\text{KNO}_3\text{-NaNO}_3$

Mol% of NaNO_3	Temperature (K)	Thermal conductivity ($\text{W} \cdot \text{m}^{-1} \cdot \text{K}^{-1}$)	Standard deviation
10	593.9	0.395	0.002 ₃
30	543.3	0.433	0.001 ₃
	566.7	0.425	0.001 ₉
	589.5	0.429	0.001 ₄
	497.5	0.462	0.002 ₄
50	509.4	0.460	0.003 ₆
	545.3	0.457	0.003 ₇
	573.7	0.446	0.004 ₇
	592.2	0.446	0.002 ₈
	546.4	0.479	0.001 ₈
75	569.6	0.471	0.003 ₁
	587.3	0.465	0.003 ₈
	592.8	0.470	0.002 ₃
100	587.7	0.511	0.001 ₃

in the calibration constant l_e , the temperature coefficient of the electrical resistance of mercury dR/dT , and the change in the unbalanced voltage against logarithm of time $d\Delta V/d\ln t$. The error in l_e was estimated as 1.5%, since the uncertainty in the thermal conductivity of toluene was 0.5% and the reproducibility of the measurements was 0.7%. The errors for dR/dT and $d\Delta V/d\ln t$ were 0.8 and 0.3%, respectively. The purity of the samples was 99.9% for KNO_3 and 99.9% for NaNO_3 . The error for the mole fraction was smaller than 0.1%. The estimated uncertainty of the measured thermal conductivity was 3%.

Measurements were performed for pure NaNO_3 and mixtures of 10, 30, 50, and 75 mol% of NaNO_3 . A mixture of 50 mol% is known as “draw salt” and is one of the industrially important heat carriers.

The present result for pure NaNO_3 is shown in Fig. 4, in which values by other authors are also plotted. Among them, the present results are the lowest. Data by McLaughlin [7] showed excellent reproducibility with no temperature dependence, although they are higher than the present results by about 8% at 593 K. Data by Gustafsson [8] at about 593 K agreed well with ours. McDonald and Davis [2] and White and Davis [9] obtained higher values than those by other authors. A possible explanation for this discrepancy is due to the convection effect, since the gap of about 2.5 mm in their concentric cylindrical apparatus seems large considering that the specimen is a high temperature liquid.

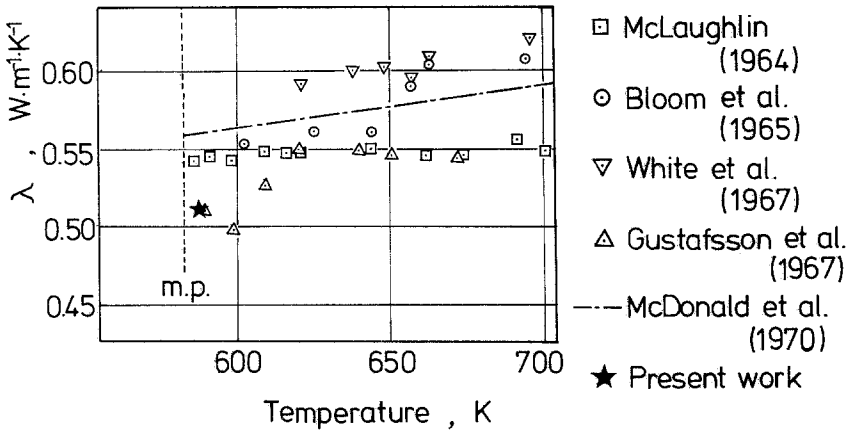

Fig. 4. Thermal conductivity of NaNO_3 .

Experimental results for the mixture are compared with those by other authors at the similar compositions as shown in Figs. 5–7. In every case, the temperature dependence of the present study was very small in the temperature range considered. But, for example, in case of the 30 mol%– NaNO_3 mixture, data by McDonald and Davis showed a positive temperature dependence, while those by Bloom et al. were negative. The results on

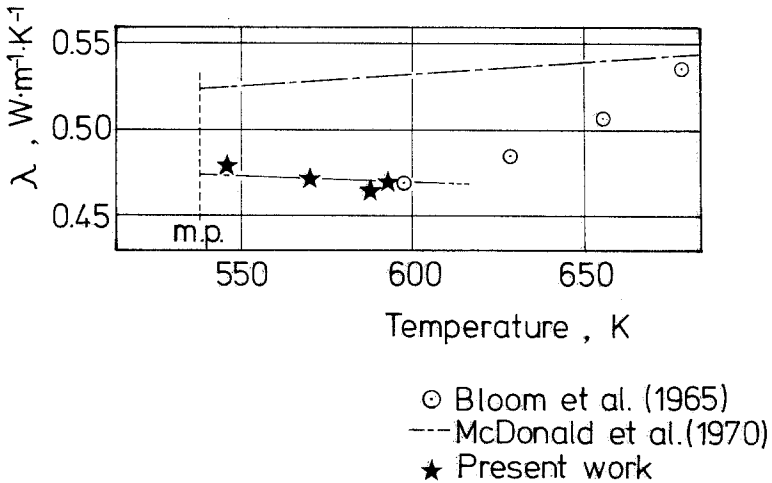

Fig. 5. Thermal conductivity of $\text{KNO}_3\text{-NaNO}_3$ mixture (25–75 mol%).

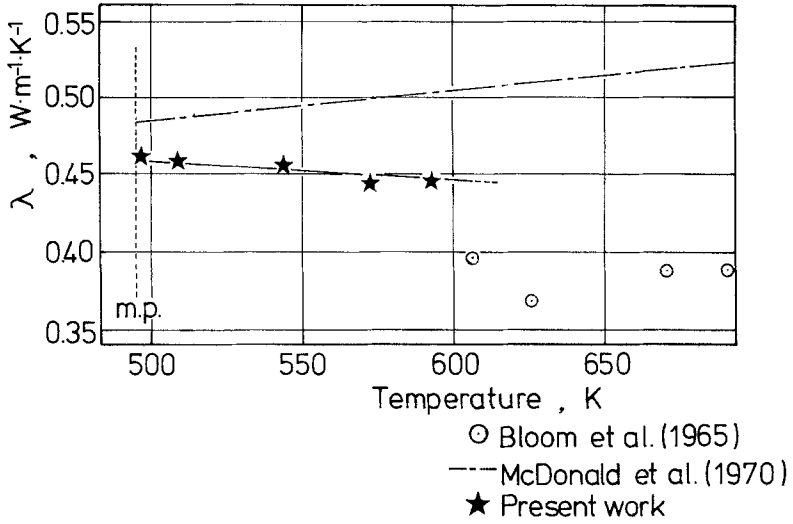

Fig. 6. Thermal conductivity of KNO_3 - NaNO_3 mixture (50-50 mol%).

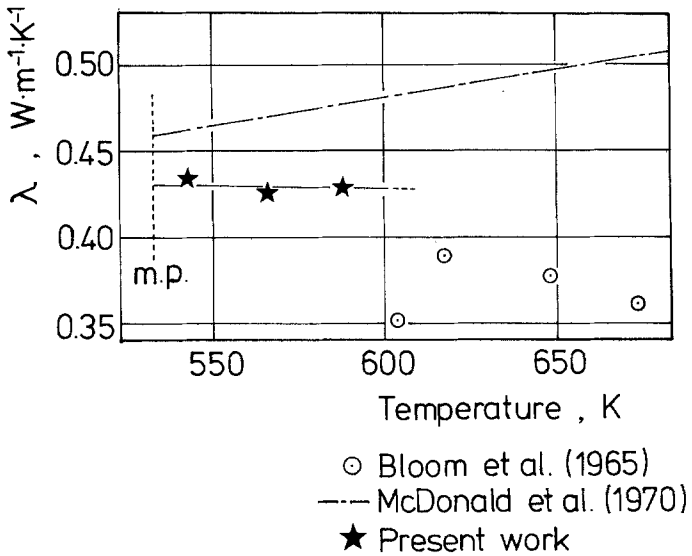

Fig. 7. Thermal conductivity of KNO_3 - NaNO_3 mixture (70-30 mol%).

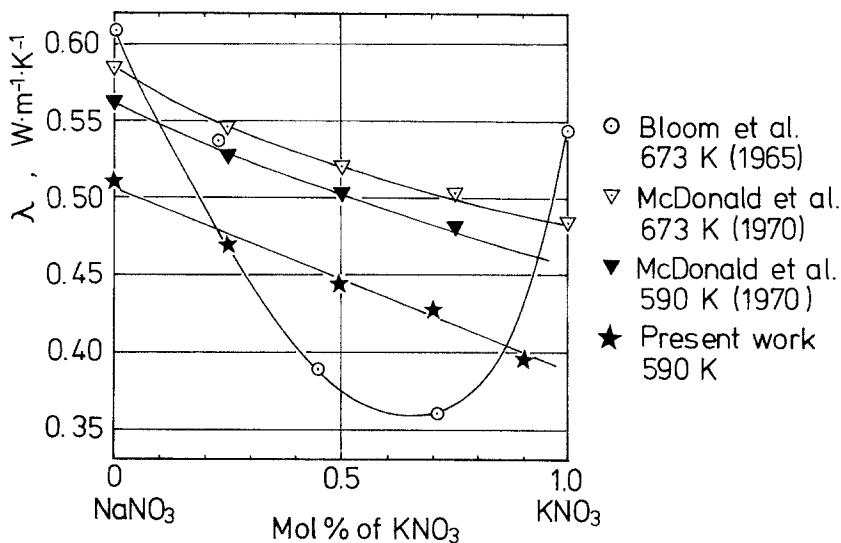

Fig. 8. Composition dependence of the thermal conductivity of KNO_3 - NaNO_3 system.

composition dependence are shown in Fig. 8. The present results at 590 K showed almost linear dependence of the thermal conductivity on the mole fraction. The gradient was very close to that of McDonald and Davis, although their values seemed too high. The discrepancies are about 10%, which exceeded the estimated experimental uncertainty of the present study. The tendency of the results of Bloom et al. is nonlinear and completely different from both the present study and that of McDonald and Davis. Also, the reproducibility of the measurements by Bloom et al. is poorer than that of ours and of the other investigators.

5. CONCLUSIONS

The thermal conductivity of the KNO_3 - NaNO_3 system was measured with a transient hot-wire apparatus using a newly developed "liquid-metal" probe. Measurements were performed on four mixtures of different compositions. Results showed that the composition dependence of this system was almost linear. Although the applicable temperature limit for the present apparatus was not high, the precision of the present measurements was better than that of the previous studies. Thus, it can be used as a reference method to check the reliability of other methods for wider temperature ranges at their lower temperature limit.

REFERENCES

1. H. Bloom, A. Doroszowski, and S. B. Tricklebank, *Aust. J. Chem.* **18**:1171 (1965).
2. J. McDonald and H. T. Davis, *J. Phys. Chem.* **74**:725 (1970).
3. Y. Nagasaka and A. Nagashima, *I & EC Fundamentals* **20**:216 (1981).
4. M. Hoshi, T. Omotani, and A. Nagashima, *Rev. Sci. Instrum.* **52**:755 (1981).
5. H. S. Carslaw and J. C. Jaeger, *Conduction of Heat in Solids*, 2nd ed. (Oxford University Press, Oxford, 1959).
6. Y. Nagasaka and A. Nagashima, *J. Phys. E: Sci. Instrum.* **14**:1435 (1981).
7. E. McLaughlin, *Chem. Rev.* **64**:389 (1964).
8. S. E. Gustafsson, *Z. Naturforsch.* **22a**:1005 (1967).
9. L. R. White and H. T. Davis, *J. Chem. Phys.* **47**:5433 (1967).